

PAPER • OPEN ACCESS

Comparison of two test methods for bending small disks on an annular support

To cite this article: V Yu Goltsev *et al* 2020 *J. Phys.: Conf. Ser.* **1431** 012014

View the [article online](#) for updates and enhancements.



IOP | ebooks™

Bringing you innovative digital publishing with leading voices to create your essential collection of books in STEM research.

Start exploring the [collection](#) - download the first chapter of every title for free.

Comparison of two test methods for bending small disks on an annular support

V Yu Goltsev^{1,*}, E G Grigoriev², A V Osintsev¹, A S Plotnikov¹ and A S Sedegov³

¹National Research Nuclear University MEPhI, Kashirskoe shosse, 31, Moscow, 115409, Russia

²Institute of Structural Macrokinetics and Materials Science Russian Academy of Sciences, Akademika Osipyana str. 8, Chernogolovka, Moscow region, 142432, Russia

³National University of Science and Technology "MISiS", Leninskiy av. 4, Moscow, 119049, Russia

*E-mail: gvy587@gmail.com

Abstract. Two methods of bending thin disks on an annular support are compared. The methods differ in the type of loading indenter and the equations that determine the strength of the material by the test results. The end surfaces of the indenter are flat cylindrical (indenter 1) or spherical (indenter 2). The methods were used to test identical disc samples from model materials: cast iron and graphite, as well as aluminum oxide samples obtained by spark-plasma sintering. The results of testing 24 disks of model materials and 10 disks of aluminum oxide on the ring support are presented. Bending diagrams of 12 disks of each model material on the annular support using two types of indentors indicate their different tensile strength. The calculated values of strength and their spread were higher when using indenter 2 than when using indenter 1. Thus, comparative tests have shown that the calculated strength of the tested materials depends on the nature of the failure of the samples and the type of bending diagram. The most reasonable were the test results obtained with the use of a flat-tipped indenter, which coincide with the characteristics of the strength of materials and the minimum spread of values.

1. Introduction.

In recent years, technologies for the consolidation of powder materials using electromagnetic fields have been actively developed [1-4]. Their advantages are high heating rate, relatively low integral temperatures, the short duration of the consolidation processes, obtaining difficult sintered powder compositions. A wide range of products manufactured by electric pulse powder consolidation has the form of small-sized disk samples with a thickness of 1 mm and a diameter of 10-15 mm [4]. Standard methods of mechanical testing for samples of such sizes are often not applicable, and to evaluate the strength properties of materials, you have to resort to alternative test methods. Methods have also been developed for determining the brittle strength of materials when testing small samples. For the first time, the method of bending thin disks on an annular support was proposed by Y. B. Friedman [5]. This method relied on the theory of plates and shells Timoshenko S. P. [6]. This method has been proposed to determine the minimum tensile strength of a material when tested in liquid nitrogen. Later this method was evolved, and it was used to determine the tensile strength of hardened steel disks with a thickness of 3-6 mm and a diameter of 60 mm [7]. In recent years, varieties of the method of bending thin disks on an annular support have appeared [8-11]. All methods are based on the Tymoshenko



theory and differ in support devices, indenters and, accordingly, different calculation formulas for determining the brittle strength of the material according to the results of testing the samples. Some of them are standardized. And, of course, the question arises about the ratio of the test results of the same samples using different methods. The purpose of this study is to compare the test results of the same disk samples from model materials: cast iron and graphite, as well as samples α -alumina obtained by the method of electropulse exposure, using two types of indenters: with a flat end surface and spherical.

2. Materials and research methods

2.1. Model materials

The model materials used are brittle materials gray cast iron SCH10 according to GOST 1412 and graphite MPG-6, the reference mechanical characteristics of which are given in Table 1.

Table 1. Strength of model materials for different types of loading

Material	σ_B^r , MPa	σ_B^b , MPa	τ_{shear} , MPa	σ_B^c , MPa
Cast iron SCH 10	100	280	110	530
Graphite MPG-6	25	34.3		73.6

Notations in Table1 are: σ_B^r – tensile strength, σ_B^b – bending strength, τ_{shear} – shear strength and σ_B^c – compressing strength. The mechanical properties of cast iron are given according to [12], graphite MPG-6 - according to [13]. The strength of cast iron was specified in a tensile test of 12 five-fold samples with a diameter of 10 mm according to GOST 1497 and 12 samples with a diameter of 8 and a height of 12 mm for compression according to GOST 25.503. The strength of MPG-6 graphite was specified when testing 4 samples for compression in accordance with GOST 25.503 and static three-point bending of flat samples with a thickness of 4 and a height of 8 mm, with a distance between supports of 40 mm. The test results were close to tabular values, except for the results of bending tests of graphite samples, the strength of which turned out to be close to the tensile strength of the material.

2.2. Aluminum oxide

Alumina discs were made by spark plasma sintering. The starting material was Al_2O_3 powder with an average particle size of the order of 1 μm of a spherical shape obtained in an electric arc discharge plasma [14]. The spark-plasma sintering process was carried out in vacuum on a LABOX-625 apparatus in a graphite mold with an internal diameter of 15 mm with a constant pressure of 50 MPa on the sintered sample. The heating rate of the samples was 100° C/min, the maximum sintering temperature was 1350° C, and the exposure at the maximum sintering temperature was 10 min. The cooling rate of the samples from the maximum sintering temperature to 600° C was 50° C / min; further cooling took place naturally when the current source was switched off. Sintered samples were disks 2-3 mm thick.

2.3. Methods of bending disk samples on an annular support

In Fig. 1 shows a diagram of the bending of a disk sample on an annular support using an indenter with a flat tip [7].

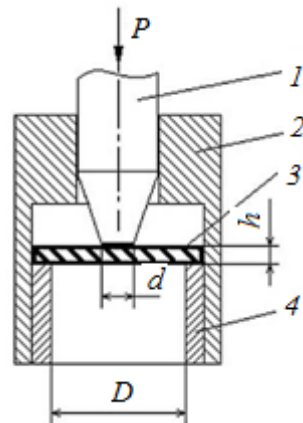

Figure 1. Scheme of testing a disk on an annular support for bending with loading by an indenter with a flat tip: 1 - indenter, 2 - holder-guide, 3 - sample, 4 - support ring

The strength of the material according to the test results of the disk is estimated by the formula:

$$\sigma = \frac{3P_{\max}}{8\pi h^2} \left[4 - (1 - \mu) \left(\frac{d}{D} \right)^2 + 4(1 + \mu) \ln \frac{D}{d} \right], \quad (1)$$

where: P_{\max} is the maximum fracture load, h is the disk thickness, μ is the Poisson's ratio, d is the diameter of the indenter's flat tip, D is the inner diameter of the support ring. In [8], the rationale for using the circuit presented in [7] for testing small disks with a diameter of 10 and a thickness of 1 mm or more is given.

In Fig. 2 shows a diagram of the bending of a disk sample on an annular support using an indenter with a spherical tip [10].

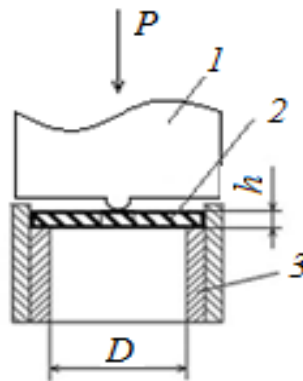

Figure 2. Scheme of testing a disk on an annular support with loading by an indenter with a spherical tip: 1 - indenter, 2 - sample, 3 - support ring

The strength of the material according to the test results of the disk is estimated by the formula:

$$\sigma = \frac{P}{h^2} \left[(1 + \mu) \left(0.485 \ln \frac{D}{2h} + 0.52 \right) + 0.48 \right]. \quad (2)$$

Here: P is the maximum load during the destruction of the sample, h is the thickness of the disk, D is the inner diameter of the support ring. Note that both formulas (1) and (2) are based on the solution of Timoshenko S.P. [6].

3. The results of the test disk samples for bending on an annular support

3.1. The results of the bending of disk samples of model materials on an annular support using two types of indenters

Thin disks made of model materials (cast iron and graphite) were tested for bending on an annular support according to the schemes shown in Figure 1 and Figure 2. The diameter of all disks is 15 mm, the diameter of the support ring is 12 mm. The tests were carried out on an Instron test machine with a maximum load of 10 kN. Table 2 shows the average test results for 6 disc samples of cast iron and 6 of graphite.

Table 2. Test results of disc samples of cast iron and graphite.

Material	Disc thickness, mm	The average strength according to the formula (1), MPa	The spread of strength values, MPa	The average strength according to the formula (2), MPa	The spread of strength values, MPa
Cast iron	1.4	481	409-592	624	487-898
Graphite	1.9	29	25-35	51	41-61

Figure 3 and Figure 4 show the load-displacement curves of bending of cast-iron discs on the annular support, and in Figure 5 and Figure 6 bending diagrams of graphite samples.

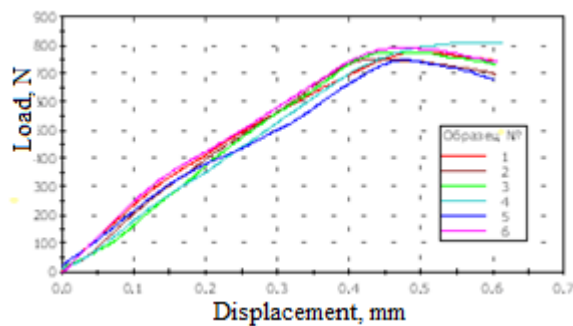

Figure 3. Bending load-displacement diagrams of cast iron discs on the annular support, a flat indenter tip is used

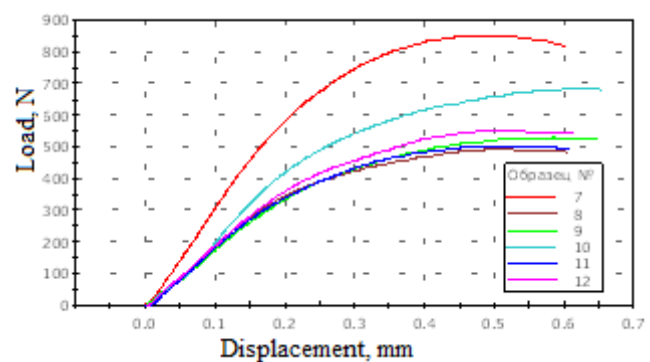

Figure 4. Bending load-displacement diagrams on the annular support of cast-iron discs, a spherical indenter tip is used

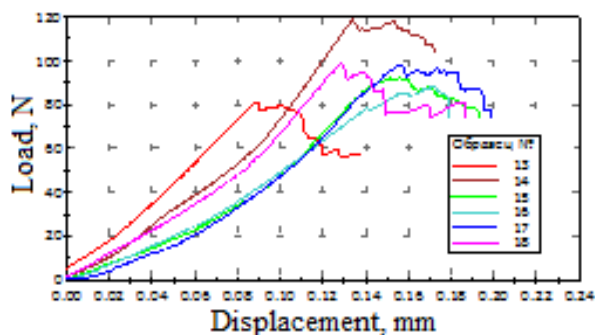

Figure 5. Bending load-displacement diagrams of graphite disks on the annular support, a flat indenter tip is used

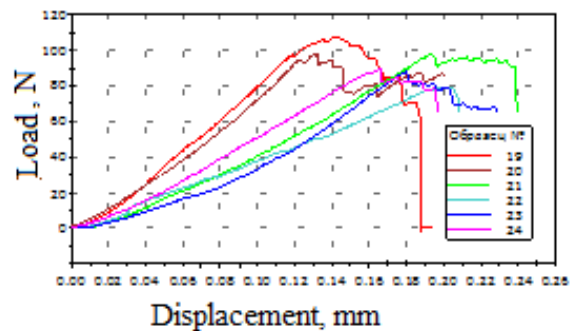

Figure 6. Bending load-displacement diagrams on the annular support of graphite disks, indenter spherical tip used

Note the different nature of the load-deflection diagrams for testing cast iron and graphite disks. Cast iron is characterized by a smooth transition through the maximum load, without jumps in cracks, which is usually inherent in plastic materials. When testing graphite samples, we observe an almost linear diagram of the load-deflection to the maximum load, and after that, the spasmodic propagation of cracks to complete destruction of the samples, characteristic of the behavior of brittle materials. The above diagrams indicate that graphite is a more fragile material than cast iron.

Analysis of the test results of thin discs made of cast iron and graphite on an annular support using two types of indenter, shown in table 2 and in Figures 3-6, allows us to draw the following conclusions:

a) The average strength results determined when testing samples using two types of indenters and, accordingly, two formulas for calculating the tensile strength of the tested materials, turned out to be different. For cast iron, using formula (2), they turned out to be 30% more, and for graphite - 75% more than according to formula (1) (see Table 2).

b) The strength of cast iron, determined by the results of a bend test of disk samples using a flat indenter, approaches the compressive strength of cast iron (481 and 530 MPa). That is, neither formula (1) nor formula (2) can be used to determine the tensile strength of materials that manifest themselves during testing as plastic materials.

c) The strength of graphite, determined by the results of a bend test of disk samples using a flat indenter, is close to the tensile strength of graphite (29 and 25 MPa). It exceeds the tensile strength (Table 1) by 15%. When using formula (2) and, accordingly, an indenter with a spherical tip, the calculated value of the tensile strength of graphite was almost 2.5 times greater than the true value (Table 1).

d) The scatter of the test results of disk samples obtained using two types of indenters was different. When using an indenter with a spherical tip, the spread in the calculated strength values was much larger than when using an indenter with a flat tip (see Table 2).

3.2. Test results on an annular support of samples of aluminum oxide Al_2O_3 obtained by SPS

Table 3 presents the results of bending on an annular support of Al_2O_3 aluminum oxide disks using two indenters.

Table 3. Test results of aluminum oxide disks

Indenter tip	Sample No.	Thickness, mm	Maximum load, N	Tensile stress at break, MPa
flat	1	2.7	1240	202
	2	3.2	1920	223
	3	2.4	1290	266
	4	3.0	2140	283
	5	3.0	2025	268
Average value				248
spherical	6	2.3	883	213
	7	3.2	2130	322
	8	2.2	713	264
	9	2.6	1270	317
	10	2.7	1750	398
Average value				303

The destruction of aluminum oxide disks was absolutely brittle with dynamic separation into small fragments at maximum load and linear bending diagrams up to failure. This destruction of the samples

is characteristic of both test methods. This point suggests that alumina is a more brittle material compared to graphite. In this regard, it can be expected that when aluminum oxide disks are bent by an indenter with a flat tip, we obtain the true tensile strength of the material, given the tendency for the calculated value of the material strength according to formula (1) to approach the true value of tensile strength with increasing brittleness (from cast iron to graphite and alumina). In this case, preference should be given to the method of testing disk samples on an annular support using an indenter with a flat tip compared to the use of an indenter with a spherical tip. The results of testing alumina disks using an indenter with a spherical tip turned out to be 22% larger and had a significantly larger scatter of values (see Table 3).

4. Conclusion

Comparative bending tests of thin small-sized disks made of model materials of cast iron and graphite and sintered from alumina powder by SPS on an annular support showed that the calculated strength of the tested materials depends on the nature of fracture of the samples, the type of bending diagram and it can represent the tensile strength (aluminum oxide), to approach him (graphite) and does not coincide with it (cast iron strength). The reliability of the results is higher for more fragile materials. Test results significantly depend on type of used indenter (with flat or spherical tips). The most reasonable results were the test results obtained using an indenter with a flat tip (coincidence with the characteristics of the strength of materials and the minimum spread of strength values). Both methods require the use of corresponding equations.

Acknowledgments

This work was financially supported by the Russian Science Foundation project no. 16-19-10213-C.

References

- [1] Munir Z A, Anselmi-Tamburini U and Ohyanagi M 2006 The effect of electric field and pressure on the synthesis and consolidation of materials: A review of the spark plasma sintering method *Journal of Materials Science* **41** 763–77. DOI: 10.1007/s10853-006-6555-2.
- [2] Yu Min, Grasso Salvatore, Mckinnon Ruth, Saunders Theo and Reece Michael J 2017 Review of flash sintering: materials, mechanisms and modeling *Advances in Applied Ceramics* **116** 1 24–60. DOI:10.1080/17436753.2016.1251051.
- [3] Menezes R R., Sout P M and Kiminami R H G A 2007 Microwave sintering of ceramics. Part I: Fundamental aspects *Ceramica* **53** 325 1-10.
- [4] Bashlykov S S, Demenyuk V D, Grigor'ev E G, Olevskii E A and Yurlova M S 2014 Electropulse consolidation of UN powder *Inorg. Mater Appl Res* **5** 278-83. DOI: 10.1134/S2075113314030034.
- [5] Fridman Y B 1952 *Mechanical properties of metals* Oborongiz (Moscow) 555.
- [6] Timoshenko S P 1940 *Theory of Plates and Shells* McGraw-Hill, (NewYork) 492
- [7] *Handbook methods of testing, control and research of engineering materials* ed Tumanov A T 1974 **2** *Methods of investigation of mechanical properties of metals* Mashinostroenie (Moscow) 320.
- [8] Goltsev V Y and Gribov N A 2017 The Use of Thin Disc Samples for the Determination of the Tear Resistance of Brittle Materials *15th Int. School-Conference New materials – Materials of innovative energy: development, characterization methods and application* KnE Materials Science 148–54. DOI: 10.18502/kms.v4i1.2139
- [9] ASTM C 1499 Standard Test Method for Montonics Equibiaxial Strength of Advanced Ceramics at Ambient Temperature.
- [10] Khaleghi E, Yen-Shan Lin, Meyers M A and Olevsky E A 2010 Spark plasma sintering of tantalum carbide *Scripta Materialia* **63** 577-80. DOI: 10.1016/j.scriptamat.2010.06.006.

- [11] ISO 6872. Dentistry–ceramic materials(Geneva) International Organization for Standardization, 2006.
- [12] Anuriev V I 2006 *Handbook on the designer-mechanical engineer* **1-3 1** Mashinostroenie (Moscow) 928
- [13] Virgiliev Y S 1974 Radiation change of structural graphite strength properties *Atomic energy* **36** 6 479-90.
- [14] Samokhin A V, Alekseev N V and Tsvetkov Y V 2006 Plasma chemical processes of creation of nanodisperse powder materials *High energy chemistry***40** 2 120-26.