

PAPER • OPEN ACCESS

## Portable neutron generator with microwave ion source for wide applications

To cite this article: M A Gorbunov *et al* 2019 *J. Phys.: Conf. Ser.* **1238** 012049

View the [article online](#) for updates and enhancements.



**IOP | ebooks™**

Bringing you innovative digital publishing with leading voices to create your essential collection of books in STEM research.

Start exploring the collection - download the first chapter of every title for free.

# Portable neutron generator with microwave ion source for wide applications

M A Gorbunov, D S Stepanov and E Y Shkolnikov

National Research Nuclear University MEPhI (Moscow Engineering Physics Institute), Kashirskoe shosse 31, 115409 Moscow, Russia

DSSStepanov@mephi.ru

**Abstract.** The paper presents the issues related to the development of a portable neutron generator with a microwave source of heavy hydrogen ions for a wide range of applications. The paper analyzes the effect of electromagnetic microwave field strength and the magnetic induction value of a constant external magnetic field on the ionization rate of molecular deuterium and determines their optimal ratios. It also describes the configuration of the magnetic system of permanent magnets made of NdFeB material, which provide a homogeneous magnetic field with an induction of 850 Gs necessary for the effective operation of the device using the electron cyclotron resonance (ECR). The dynamics of the primary deuteron flux, as well as secondary particles in the ion-optical system are analyzed. Elements of a conceptual design of a portable neutron generator are described.

## 1. Introduction

At present, there is a strong tendency to expand the use of portable neutron generators and create new promising technologies based on them. At the same time, the requirements to the technical and operational characteristics of such generators are substantially being increased, that essentially means the development of their new generation.

A special place in experimental development is occupied by neutron generators with a microwave ion source using the ECR. The absence of electrodes in the microwave discharge makes it possible to avoid contamination on insulators and electrodes in the ion extraction and acceleration system. The effect of ECR significantly increases the energy deposition into the plasma, which leads to a high degree of ionization and energy efficiency, and also to the formation of a high fraction of monoatomic ions. Experimental samples of portable neutron generators show high values of the operational life of ~ 5000 hours and neutron fluxes from  $10^{10}$  n/s with the D (d,n)<sup>3</sup>He reaction and up to  $10^{12}$  n/s with the T (d,n)<sup>4</sup>He reaction [1].

## 2. Microwave resonator

The basis of a neutron generator is a microwave ion source, which is a resonator filled with molecular deuterium. The resonator itself has a prismatic shape and is powered by a microwave generator with a frequency of 2.45 GHz in the H<sub>101</sub> mode. When microwave power enters the resonator, the "background" electrons in it acquire the energy necessary for ionization of molecular deuterium. However, without using additional effects that contribute to the absorption of microwave energy by electrons, tens of kilowatts of power are required to ignite such a discharge, that makes it impossible



to build the portable design of such a generator. To increase the efficiency of microwave power absorption, the ECR effect is used [2]. The effect of the magnitude of the magnetic induction on the efficiency of the absorption of the microwave field energy by electrons is given in [3]. To determine the requirements for the magnetic system that forms the distribution of the magnetic field, a detailed analysis of the ionization processes in the microwave plasma is carried out below.

To analyze the concentration dynamics and temperature of plasma components of a microwave discharge in the resonator, a kinetic scheme of nonequilibrium processes in deuterium was used, as well as the energy balance equations that take into account the heating of electrons by the microwave field, as well as the transfer of energy from electrons to heavy particles. This scheme takes into account the following reactions:

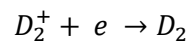
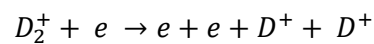
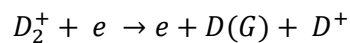
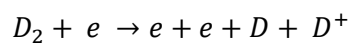
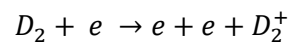
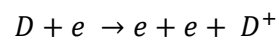
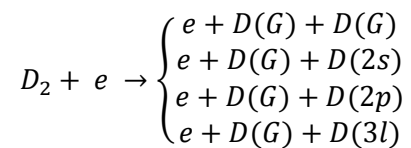

The solution of the corresponding set of equations makes it possible to relate the electric field strength in the resonator and the magnitude of the magnetic field with the plasma parameters. Thus, for example, the analysis of these solutions for the electric microwave field strength equal to  $2 \cdot 10^4$  V/m (minimum value at which the discharge can evolve) showed (see figure 1) that the values of the magnetic field induction of about 850 Gs correspond to the most optimal mode of operation. At the same time, electrons energy losses in inelastic collisions limit the growth of their temperature at a level of 30 eV. Exceeding this value will involve excessive heating of the electronic plasma component and a decrease in the ionization rate.

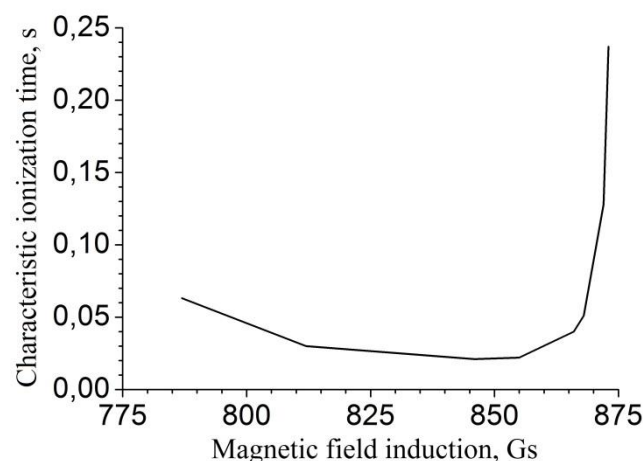

Figure 1. The dependence of the characteristic ionization time on the magnitude of the magnetic induction

To create the required magnetic field distribution, a magnetic system consisting of 8 plates of the permanent NdFeB magnets and two adjusting iron plates was developed (figure 2 (a)). Such an assembly provides a fairly uniform distribution of the magnitude of the magnetic induction  $B \sim 850$  Gs

in most of the resonator volume (figure 2 (b)). The distribution of the amplitude of the electric field in the  $H_{101}$  mode has a sinusoidal nature, so if the region of strong electric fields and weak cyclotron resonance (the reverse situation is also possible) is chosen as a mode of operation of the resonator, then there is no particular reason to maintain a uniform magnetic field in the entire volume of the resonator, as this will require increasing the size of the magnetic system itself. Under these conditions, it is sufficient to use the region of the maximum of the electric field lying in the range from 20 to 60 mm along the resonator.

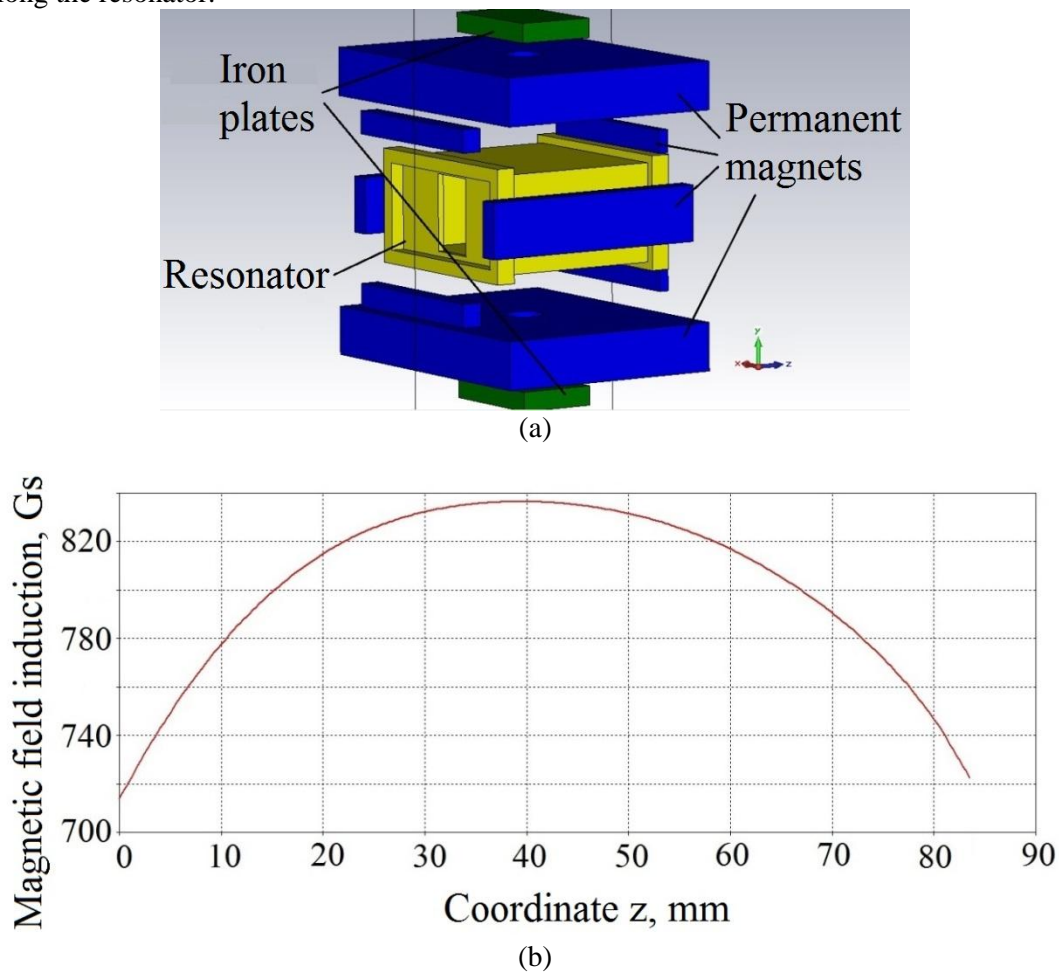

Figure 2. The magnetic system of the microwave resonator: (a) - the relative location of the magnets, (b) the distribution of the magnetic field induction along the axis of the resonator

The residual induction of permanent magnets varies from 0.8 kGs for correcting magnets and up to 1.4 kGs for main magnets. The magnetic field is adjusted by vertical displacement of the ferromagnetic plates. Such a mechanism is necessary for finding the operating conditions of a discharge.

### 3. Ion-optical system

The process of accelerating and transporting a neutron-forming beam from the ion source to the target is very important for the quality of the operating characteristics of a neutron generator. The dynamics of secondary beams produced in the volume of the ion-optical system (IOS) and in the target assembly is also of considerable importance here. The lack of proper focusing of the ion beam entails sputtering the electrodes of the IOS, which leads, among other things, to the appearance of a conducting layer on the surface of the high-voltage insulator and to further electrical breakdown. In addition, a strong

inhomogeneity in the cross section of the beam leads to local overheating of the target and a decrease in the resource of its stable operation. Also, the design of the IOS should include the locking of secondary electrons that arise when the target is bombarded with the ion beam.

To analyze the dynamics of charged particle flows in the IOS, the KARAT package was used [4]. The voltage at the pulling electrode is -45 kV and at the target assembly -100 kV. The injection of the deuterium ion beam occurs with an equipotential of -500 V and located on the boundary of the resonator. The deuteron flux with a current of 30 mA shown in figure 3 does not deposit on the electrodes, and also creates a fairly uniform spot on the target surface (figure 4).

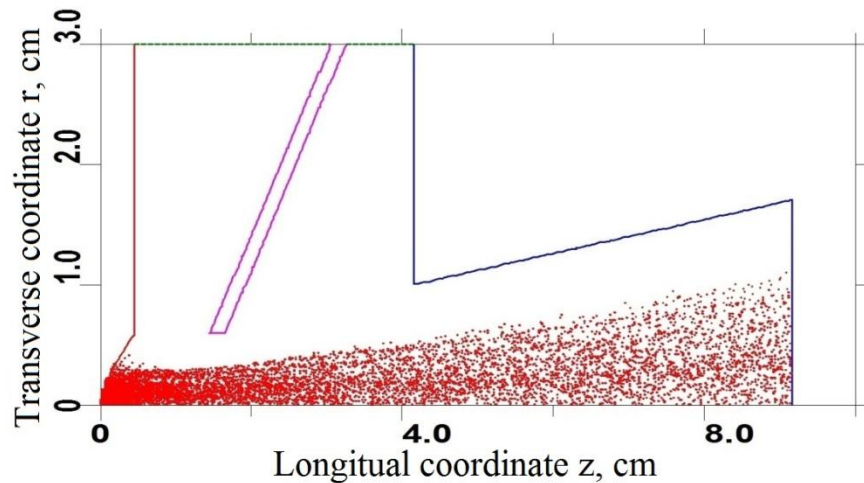

Figure 3. The deuteron flux in the ion-optical system

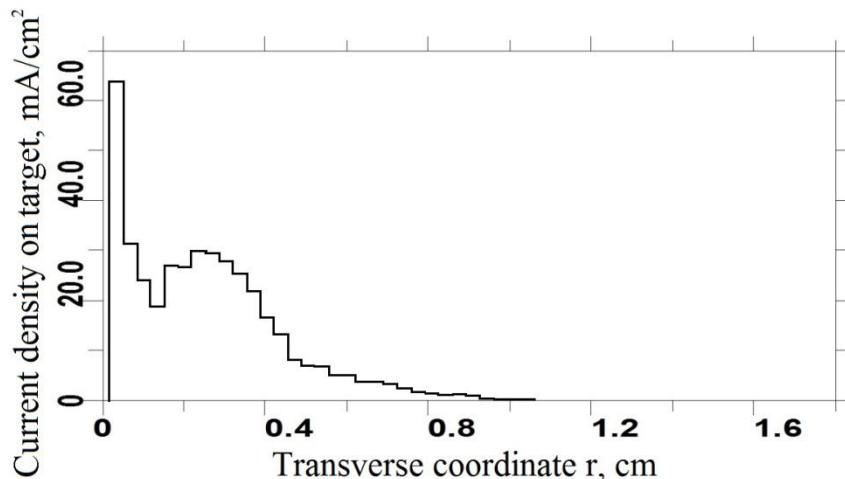

Figure 4. Distribution of the current density on the target

Suppression of secondary electrons knocked out of the target by the ion beam occurs by means of a magnetic field generated by permanent magnets located behind the target assembly. The secondary electrons emerging from the target settle on the inner surface of the target electrode under the action of a magnetic field and under the condition of a weak electric field. The secondary electrons formed as a result of ionization by the deuterium particle beam of the residual gas do not fall under the action of a magnetic field and form a beam with a current equal to 0.4 mA and an average energy of 50 keV at the resonator output port.

#### 4. Design of a neutron generator

The designed model of a neutron generator is shown in figure 5. The prismatic microwave resonator at a frequency of 2.45 GHz is mounted on the supporting flange. Microwave power enters the resonator

through a rectangular waveguide with a special vacuum microwave window. In the waveguide section, vacuum fixtures are mounted, which also ensure the flow of molecular deuterium. The ECR is provided by a system of permanent magnets mounted around the resonator together with a system for their adjustment. The system is pumped to a pressure of  $10^{-3}$  Torr through the hole in the supporting flange. The ion-optical system with a target assembly is mounted on the opposite side of the flange. Behind the target assembly, outside the vacuum volume, there is a system of magnets that suppresses secondary electron emission from the surface of the target. The system of water or air cooling is also integrated in the magnetic system. The entire system has an overall dimensions of 300x600 mm.

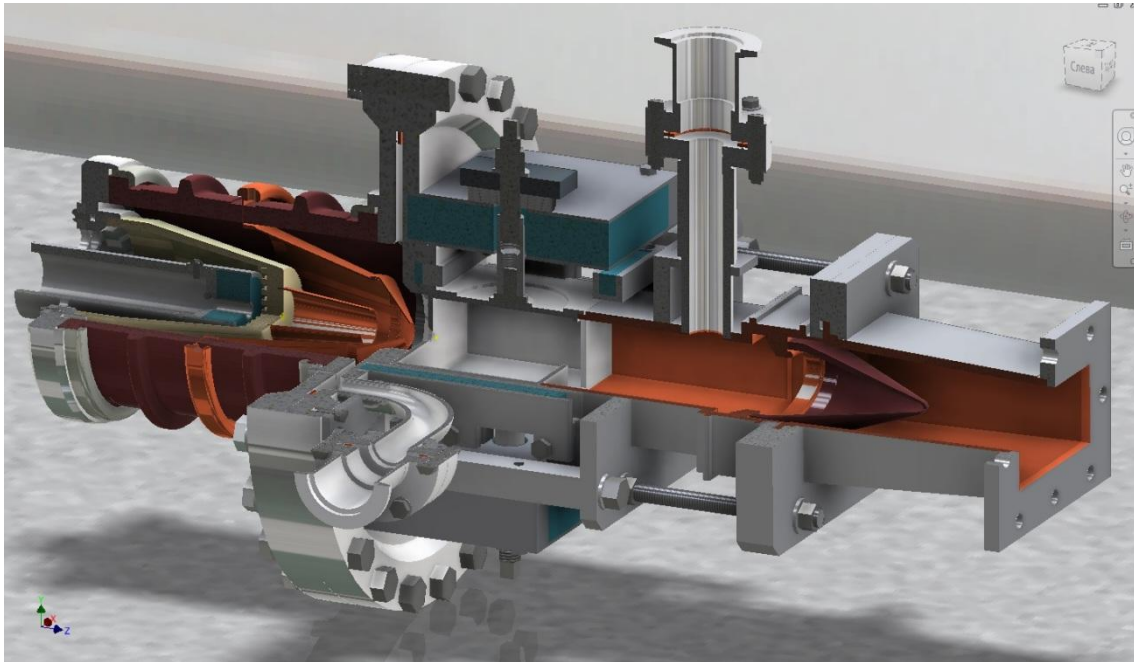

Figure 5. The designed model of a neutron generator

## 5. Conclusion

The results presented above made it possible to develop a conceptual design documentation for an experimental sample of a portable neutron generator with a microwave ion source in the electron cyclotron resonance mode. The neutron generator has connection ports to all necessary auxiliary devices: microwave path at 2.45 GHz, vacuum system, external source of molecular deuterium as well as air or liquid cooling systems. The design also includes adjusting the resonator to the operating frequency in the conditions of burning a microwave discharge and the variation in the distribution of the magnetic field in order to find the optimal operating mode.

## Acknowledgement

The work was supported by the Ministry of Science and Education of the Russian Federation under the agreement № 14.575.21.0169 (RFMEFI57517X0169).

## References

- [1] Bogdanovich B Yu, Didenko A N, Nesterovich A V et al. Neutron generators based on superhigh-frequency sources of heavy hydrogen nuclides (review). *2015 Insts. and Exper. Tech.* 4 p 5-13
- [2] Ginzburg V L, Rukhadze A A 1975 *Waves in magnetoactive plasma* (Moscow: Nauka) p 254
- [3] Stepanov D S, Chebotarev A V, Shkolnikov E Ya Electromagnetic Field in the Resonator of Neutron Generator's Hydrogen Ion Source *2016 Proc. Int. Conf. APEDE* 2 7879076.

- [4] Tarakanov V P «User's Manual for Code KARAT», BRA Inc., Va, USA,(1992)